

SERIES 500

contrec

FLOW COMPUTER

Model 515

STEAM FLOW
NATURAL GAS FLOW



Features

- Two configurable frequency inputs
- Four configurable analog inputs
- Four logic inputs
- Selectable communications protocol on serial ports including Modbus RTU
- Infra-red communications port on front panel
- Isolated 4-20mA outputs for retransmission
- Isolated pulse outputs for retransmission
- Pulse width and scaling of pulse output
- Up to four relay outputs
- RTC logging
- Front panel adjustment of 8-24V DC output voltage
- Backlit display
- LCD backup



The model 515 is a flow computer with full rate-totalizing functions suitable for complex applications such as Natural Gas and Steam.

General Overview

The 515 is the advanced model in the 500 series. It has more inputs and outputs of higher accuracy giving it greater capabilities and configurability to suit a wide range of applications.

There are multiple frequency and analog inputs which make it suitable for applications that require extra external sensors for temperature, pressure, density, level devices and so on.

The Model 515 is capable of operating in a wide temperature range and its "plug and play" option card makes enhancements easy without reprogramming. The behaviour of the instrument is determined by the instrument software which is selected from an increasing list of applications in the 500 Series Program Manager.

A snap-in front panel strip with front key functions is available to suit the particular type of application, such as rate totalising or batch controlling.

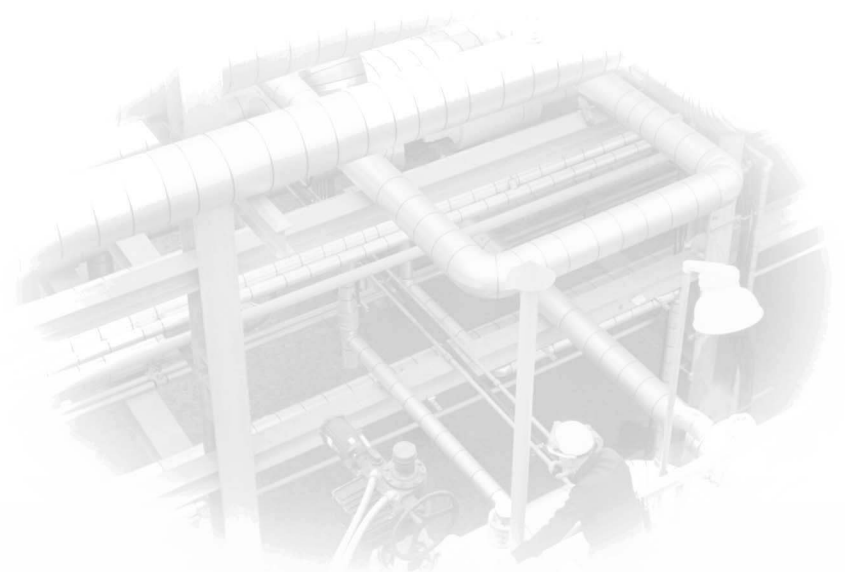

Accuracy • Quality • Performance

Software Configuration

The instrument can be further tailored to suit specific application needs including units of measure, custom tags, second language or access levels. A distributor can configure these requirements before delivery.

Most other parameters can be programmed in the field, according to the user-access levels assigned to the parameters by the distributor.

Displayed Outputs

The front panel display shows the current values of the input variables and the results of the calculations.

The instrument can be supplied with a real-time clock for data logging of up to 100 entries of the first ten variables as displayed on the main menu.

Communications

There are three communication ports available as follows:

- RS-232 serial port (standard)
- RS-485 port (advanced option)
- Infra-red port (on front panel)

These ports are available for remote meter reading and for initial application loading of the instrument.

Isolated Outputs

The two opto-isolated outputs in the advanced option can retransmit any main-menu variable. The type of output is determined by the nature of the assigned variable. Totals are output as pulses and rates are output as 4-20mA signals.

Relay Outputs

The relay alarms can be assigned to any of the main menu variables of a rate type. The alarm can be fully configured including hysteresis. Two relays are standard with four available in the advanced option.

Terminal Designations

Terminal Label		Designation		Comment
1	FINP	1+	Frequency Input 1+	
2	FINP	2+	Frequency Input 2+	
3	SG	-	Signal ground	
4	EXC V	1+	Excitation Term 1+	For AINP1 For AINP2
5	EXC V	2+	Excitation Term 2+	
6	EXC V	3+	Excitation Term 3+	
7	AINP1	+	Analog input ch 1 (+)	
8		-	Analog input ch 1 (-)	
9	AINP2	+	Analog input ch 2 (+)	
10		-	Analog input ch 2 (-)	
11	AINP3	+	Analog input ch 3 (+)	
12		-	Analog input ch 3 (-)	
13	AINP4	+	Analog input ch 4 (+)	
14		-	Analog input ch 4 (-)	
15	Vo	+	8-24 volts DC output	Overload protected
16	G	-	DC Ground	
17	Vi	+	DC power input	DC power in 12-28V
18	SH	E	Shield terminal	
19	RS485	+	RS485 data in (+)	Advanced option
20		-	RS485 data out (-)	
21		G	RS485 ground	
22	LOGIC INPUTS	1+	Switch 1	Advanced option
23		2+	Switch 2	
24		3+	Switch 3	
25		4+	Switch 4	
26		C-	Signal ground	
27	OUT 1	+	Output ch 1 (+)	Advanced option
28		-	Output ch 1 (-)	
29	OUT 2	+	Output ch 2 (+)	Advanced option
30		-	Output ch 2 (-)	
31	RELAYS	RC	Relay common	Standard version
32		R1	Relay 1	
33		R2	Relay 2	Advanced option
34		R3	Relay 3	
35	R4	Relay 4		
E	AC MAINS	E	Mains ground	AC power in 95-135V or 190-260V
N		N	Mains neutral	
A		A	Mains active	
RS232 port		9-pin serial port		Standard version

Specifications

General

Operating Environment

PCB Protection - Conformal Coating

Temperature	-20°C to +60°C
Humidity	0 to 95% non condensing

PCB Protection - None

Temperature	+5°C to +40°C
Humidity	5% to 85% non condensing

Power Supply	95 to 135 volts AC or 190 to 260 volts AC or 12 to 28 volts DC
--------------	--

Power Cons.	Typically 6W
Protection	Sealed to IP65 (Nema 4X) when panel mounted

Dimensions	147mm (5.8") width 74mm (2.9") height 166mm (6.6") depth
------------	--

Keypad	5 embossed tactile keys
--------	-------------------------

Display

Type	LCD with 7-digit numeric display and 11-character alphanumeric display
Digits	15.5mm (0.6") high
Characters	6mm (0.24") high
LCD Backup	Last data visible for 15min after power down (optional)
Update Rate	0.3 second

Approvals

Interference	CE compliance
Enclosure	CENELEC, FM, CSA and SAA approved enclosures available for hazardous areas

Inputs

Frequency Input (General)

Number of inputs	2 configurable inputs
Range	0 to 10kHz
Overvoltage	30V maximum
Update Time	0.3 sec
Cutoff frequency	Programmable (default at 0.25Hz)
Configuration	Pulse, coil or NPS input

Pulse

Signal Type	CMOS, TTL, open collector, reed switch
Threshold	1.3 volts

Coil

Signal Type	Turbine and sine wave
Sensitivity	15mV p-p minimum

NPS

Signal Type	NPS sensor to Namur standard
-------------	------------------------------

Logic Inputs

Signal Type	CMOS, TTL, open collector, reed switch
Number of inputs	4 inputs

Analog Input (General)

Number of inputs	4 configurable inputs
Overcurrent	100mA maximum
Update Time	< 1.0 sec
Configuration	4-20mA, 0 to 5 volts (AINP1 to AINP4) RTD (AINP1 and AINP2 only)

RTD Input (AINP1 and AINP2 only)

Sensor Type	PT100 to IEC 751
Connection	Four Wire
Range	-100°C to 300°C
Accuracy	0.1°C typical

4-20mA Input (AINP1 to AINP4)

Impedance	100ohms (to common signal ground)
Accuracy	0.05% full scale (20°C) 0.1% (full temperature range, typical)

0-5 Volts Input (AINP1 to AINP4)

Impedance	10Mohms (to common signal ground)
Accuracy	0.05% full scale (20°C) 0.1% (full temperature range, typical)

Outputs

Relay Output

No. of Outputs	2 relays plus 2 optional relays
Voltage	250 volts AC, 30 volts DC maximum
Current	3A maximum

Communication Ports

Ports	RS-232 port (standard) RS-485 port (optional) Infra-red port (standard)
Baud Rate	2400 to 19200 baud
Parity	Odd, even or none
Stop Bits	1 or 2
Protocols	ASCII or Modbus RTU

Transducer Supply

Voltage	8 to 24 volts DC, programmable
Current	70mA @ 24V DC, 120mA @ 12V DC max
Protection	Power limited output

Isolated Output (Optional)

No. of Outputs	2 configurable outputs
Configuration	Pulse or 4-20mA output

Pulse Output

Signal Type	Open collector
Switching	200mA, 30 volts DC maximum
Saturation	0.8 volts maximum
Width	Programmable: 10ms, 20ms, 50ms, 100ms, 200ms, 500ms

4-20mA Output

Supply	8 to 30 volts DC external
Resolution	0.05% full scale
Accuracy	0.05% full scale (20°C) 0.1% (full temperature range, typical)

Real Time Clock (Optional)

Battery Type	3 volts Lithium button cell (CR2032)
Battery Life	5 years (typical)

Important: Specifications are subject to change without notice.

Product Codes

Model	Supplementary Code	Description
515	-	
Enclosure	1	Panel mount enclosure
	2	Field mount enclosure (not yet available)
	3	Explosion proof Ex410 with metric glands
	4	Explosion proof Ex410 with NPT glands
Output Options	0	Basic: – 9 way DB RS232 serial port and 2 relays
	1	Advanced - also includes RS485 port, 4 relays, 2 isolated 4-20mA or pulse outputs, 4 logic inputs and time-based logging
Extra Options	0	None
	1	Reserved
Power Supply	E	For 220/240 VAC
	A	For 110/120 VAC
	D	For DC power only 12-28 VDC
Display Panel Option	F	Fully optioned (with backlight, LCD backup and Infra-Red comms port)
PCB Protection	C	Conformal coating - required for maximum environmental operating range. Recommended to avoid damage from moisture and corrosion.
	N	None - suitable for IEC standard 654-1 Climatic Conditions up to Class B2 (Heated and/or cooled enclosed locations)
Application Pack Number	XXnn	Defines the application software to be loaded into the instrument
For example: Model No. 515.110EFC Displayed on the 500 Series as: (only h/w that affects the operation is represented)		- 10 - F - 515 MODEL

Example full product part number is 515.110EFC-XXnn (This is the number used for placing orders).

Part Number

515-XXXXXX-XXnn
see Product Code to select required features

Default Application software:
515-XXnn-000000

Dimension Drawings

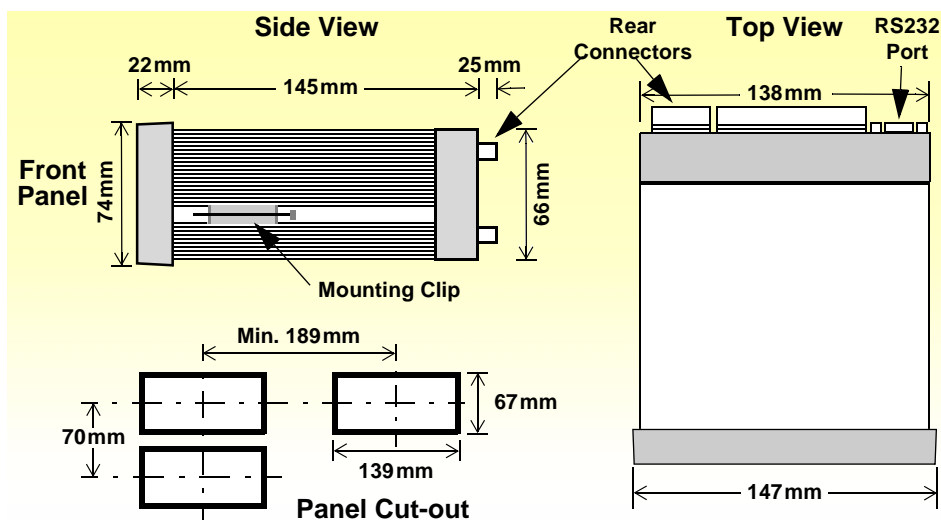

www.contrec.com.au

Contrec Pty Ltd

22 Hall Street Hawthorn East
Victoria 3123 AUSTRALIA
Tel: +61 3 9822 8966 Fax: +61 3 9822 8329
Email: sales@contrec.com.au

Contrec Europe Limited

PO Box 436 Sowerby Bridge,
West Yorkshire HX6 3YA, UK
Tel: +44 1422 829 940 Fax +44 1422 829 941
Email: sales@contrec.co.uk

Contrec - USA, LLC

916 Belcher Drive, Pelham AL 35124 USA
Tel: (205) 685 3000 Fax: (205) 685 3001
Email: contrec@contrec-usa.com

A Delft Instruments company